

# MOUNTING PLATES

## 連結盤

- ◆ 各種鼻端規格，干島連結盤均能選配使用。
- ◆ "Chadox" mounting plates are available to any kinds of spindle noses.

### 尺寸圖 » Dimensions



圖-1 Fig.1



圖-2 Fig.2

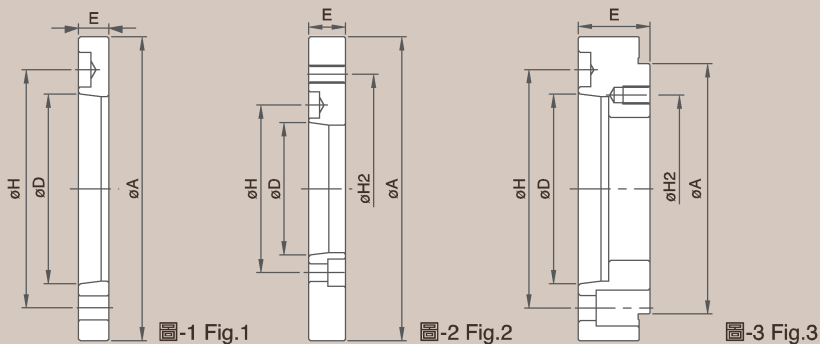

圖-3 Fig.3

### 規格表 » Specifications

型式/規格 MODEL /SPEC.	鼻端番號 Nose of Spindle D	A	H	H2	E	參考圖 Reference Drawing
T005A <sub>2</sub> 4	A <sub>2</sub> 4	110	82.6	--	20	圖-1 fig.1
T006A <sub>2</sub> 5	A <sub>2</sub> 5	140	104.8	--	15	圖-1 fig.1
T008A <sub>2</sub> 6	A <sub>2</sub> 6	170	133.4	--	17	圖-1 fig.1
T010A <sub>2</sub> 8	A <sub>2</sub> 8	220	171.4	--	18	圖-1 fig.1
T012A <sub>2</sub> 8	A <sub>2</sub> 8	220	171.4	--	18	圖-1 fig.1
T015A <sub>2</sub> 11	A <sub>2</sub> 11	300	235	--	22	圖-1 fig.1
T018A <sub>2</sub> 11	A <sub>2</sub> 11	300	235	--	22	圖-1 fig.1
T021A <sub>2</sub> 15	A <sub>2</sub> 15	380	330.2	--	27	圖-1 fig.1
T024A <sub>2</sub> 20	A <sub>2</sub> 20	520	463.6	--	27	圖-1 fig.1
T032A <sub>2</sub> 15	A <sub>2</sub> 15	380	330.2	--	27	圖-1 fig.1
T040A <sub>2</sub> 15	A <sub>2</sub> 15	380	330.2	--	27	圖-1 fig.1

單位/UNIT:mm

型式/規格 MODEL /SPEC.	鼻端番號 Nose of Spindle D	A	H	H2	E	參考圖 Reference Drawing
T004A <sub>2</sub> 4	A <sub>2</sub> 4	85	82.6	70.6	40	圖-3 fig.3
T005A <sub>2</sub> 5	A <sub>2</sub> 5	110	104.8	82.6	45	圖-3 fig.3
T006A <sub>2</sub> 4	A <sub>2</sub> 4	140	82.6	104.8	20	圖-2 fig.2
T006A <sub>2</sub> 6	A <sub>2</sub> 6	140	133.4	104.8	40	圖-3 fig.3
T008A <sub>2</sub> 5	A <sub>2</sub> 5	170	104.8	133.4	23	圖-2 fig.2
T008A <sub>2</sub> 8	A <sub>2</sub> 8	170	171.4	133.4	45	圖-3 fig.3
T010A <sub>2</sub> 6	A <sub>2</sub> 6	220	133.4	171.4	28	圖-2 fig.2
T012A <sub>2</sub> 6	A <sub>2</sub> 6	220	133.4	171.4	28	圖-2 fig.2
T012A <sub>2</sub> 11	A <sub>2</sub> 11	220	235	171.4	54	圖-3 fig.3
T015A <sub>2</sub> 8	A <sub>2</sub> 8	300	171.4	235	33	圖-2 fig.2
T018A <sub>2</sub> 8	A <sub>2</sub> 8	300	171.4	235	33	圖-2 fig.2
T021A <sub>2</sub> 8	A <sub>2</sub> 8	380	171.4	330.2	41	圖-2 fig.2
T021A <sub>2</sub> 11	A <sub>2</sub> 11	380	235	330.2	41	圖-2 fig.2
T024A <sub>2</sub> 11	A <sub>2</sub> 11	520	235	463.6	42	圖-2 fig.2
T024A <sub>2</sub> 15	A <sub>2</sub> 15	520	330.2	463.6	42	圖-2 fig.2
T032A <sub>2</sub> 11	A <sub>2</sub> 11	380	235	330.2	41	圖-2 fig.2
T040A <sub>2</sub> 11	A <sub>2</sub> 11	380	235	330.2	41	圖-2 fig.2