

強力超薄型夾盤

1. 把手和盤面成30°角，旋轉操作更便利。
2. 薄型設計，可增加機械加工之容許長度。
3. 外徑成凸緣設計，裝卸容易。
4. 強力型設計可共用生爪。

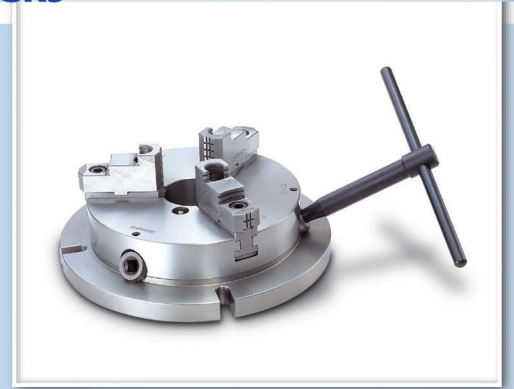

尺寸圖 » Dimensions

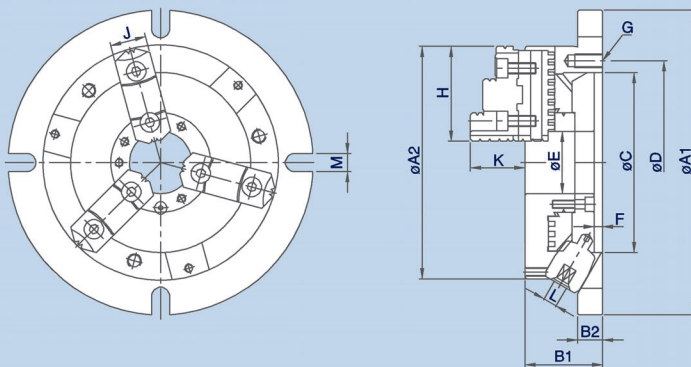

1. The handle with an angle of 30 degrees is much convenient for operations.
2. The "super thin thickness" design of chucks increase the "allowable distance" of machining operations.
3. Chuck flange makes loading and unloading operations simpler and more convenient.
4. Hard jaws and Soft jaws can be used alternatively.

規格表 » Specifications

單位/UNIT:mm

型式/規格 MODEL / SPEC.	A1	A2	B1	B2	C	D
NBK-06	220	170	58	18	130	147
NBK-08	270	210	65	20	155	172
NBK-10	315	255	73	20	190	210
NBK-12	370	305	80	22	250	285
NBK-16	470	405	105	24	345	375
NBK-20	570	500	121	29	420	458

型式/規格 MODEL / SPEC.	E	F	G	H	J	K
NBK-06	45	6	3-M10x1.5P	68	26	40
NBK-08	60	6	3-M10x1.5P	82	28	43
NBK-10	80	6	3-M12x1.75P	93	32	52
NBK-12	105	5	3-M12x1.75P	118	40	59
NBK-16	160	7	6-M14x2P	150	50	75
NBK-20	220	7	6-M16x2P	140	55	84

型式/規格 MODEL / SPEC.	L	M	把握範圍 Max.Gripping Diameter		淨重 Weight (kg)
			外徑把握 O.D.Clamping (mm)	內徑把握 I.D.Clamping (mm)	
NBK-06	10	13	ø8~ø160	ø48~ø150	10.6
NBK-08	11	13	ø11~ø200	ø62~ø190	18.1
NBK-10	12	16	ø12~ø250	ø72~ø240	27.9
NBK-12	14	18	ø15~ø300	ø86~ø290	42.9
NBK-16	15	18	ø60~ø410	ø145~ø388	--
NBK-20	19	18	ø86~ø500	ø245~ø488	150