

# CL, CLT SOLID POWER CHUCKS

## 中實油壓夾頭

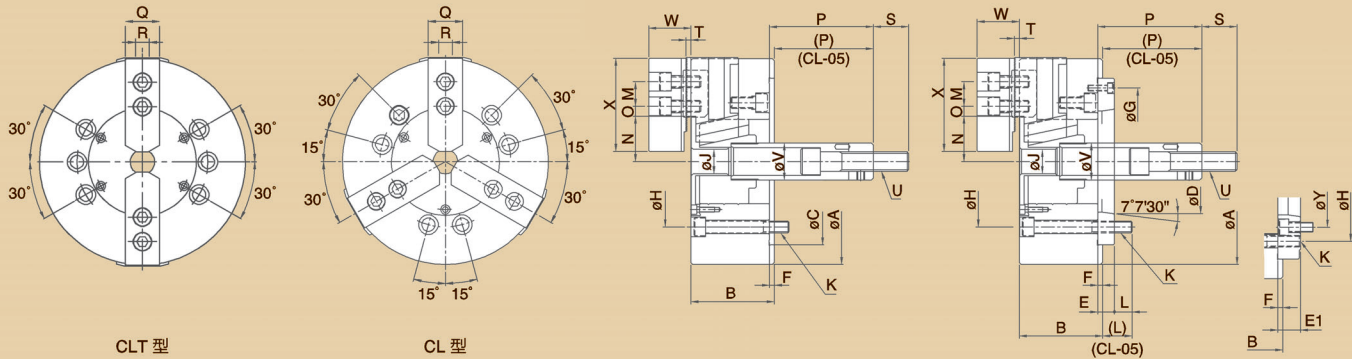

### 尺寸圖 >> Dimensions



### 規格表 >> Specifications

單位/UNIT:mm

| 型式/規格<br>MODEL<br>/SPEC. | 主軸鼻端番號<br>Nose Of<br>Spindle         | A   | B   | C<br>(H6) | D       | E  | E1 | F | G   | H     | J  | K           | L  | M  |
|--------------------------|--------------------------------------|-----|-----|-----------|---------|----|----|---|-----|-------|----|-------------|----|----|
| CL-05                    | A <sub>2</sub> -4                    | 135 | 55  | 80        | 63.513  | -- | -- | 7 | --  | 100   | -- | 3-M8x1.25P  | 14 | 14 |
| CL-06                    | A <sub>2</sub> -5                    | 165 | 74  | 140       | 82.563  | 15 | -- | 5 | 116 | 104.8 | 21 | 6-M10x1.5P  | 19 | 20 |
| CL-08                    | A <sub>2</sub> -6(A <sub>2</sub> -5) | 210 | 85  | 170       | 106.375 | 17 | 23 | 5 | 150 | 133.4 | 25 | 6-M12x1.75P | 18 | 25 |
| CL-10                    | A <sub>2</sub> -8(A <sub>2</sub> -6) | 254 | 89  | 220       | 139.719 | 18 | 28 | 5 | 190 | 171.4 | 34 | 6-M16x2P    | 25 | 30 |
| CL-12                    | A <sub>2</sub> -8                    | 304 | 106 | 220       | 139.719 | 18 | -- | 6 | 190 | 171.4 | 34 | 6-M16x2P    | 20 | 30 |
| CLT-06                   | A <sub>2</sub> -5                    | 165 | 74  | 140       | 82.563  | 15 | -- | 5 | 116 | 104.8 | 21 | 6-M10x1.5P  | 19 | 20 |
| CLT-08                   | A <sub>2</sub> -6(A <sub>2</sub> -5) | 210 | 85  | 170       | 106.375 | 17 | 23 | 5 | 150 | 133.4 | 25 | 6-M12x1.75P | 18 | 25 |
| CLT-10                   | A <sub>2</sub> -8(A <sub>2</sub> -6) | 254 | 89  | 220       | 139.719 | 18 | 28 | 5 | 190 | 171.4 | 34 | 6-M16x2P    | 25 | 30 |
| CLT-12                   | A <sub>2</sub> -8                    | 304 | 106 | 220       | 139.719 | 18 | -- | 6 | 190 | 171.4 | 34 | 6-M16x2P    | 20 | 30 |

| 型式/規格<br>MODEL<br>/SPEC. | N<br>max. | N<br>min. | O<br>max. | O<br>min. | P<br>max. | P<br>min. | Q  | R  | S  | T | U         | V  | W  | X   | Y     |
|--------------------------|-----------|-----------|-----------|-----------|-----------|-----------|----|----|----|---|-----------|----|----|-----|-------|
| CL-05                    | 30.4      | 27.2      | 17.1      | 6.55      | 9         | -6        | 25 | 10 | 35 | 2 | M12x1.75P | 28 | 31 | 62  | --    |
| CL-06                    | 37.5      | 33.2      | 15.1      | 7.6       | 101.5     | 81.5      | 31 | 12 | 36 | 4 | M16x2P    | 34 | 39 | 73  | --    |
| CL-08                    | 46.3      | 41.9      | 22.1      | 8.6       | 127       | 106       | 35 | 14 | 36 | 5 | M20x2.5P  | 38 | 42 | 95  | 104.8 |
| CL-10                    | 51.4      | 47        | 30.6      | 9.6       | 158       | 133       | 40 | 16 | 36 | 5 | M20x2.5P  | 45 | 46 | 110 | 133.4 |
| CL-12                    | 60.63     | 55.32     | 48.55     | 20.05     | 163       | 133       | 50 | 18 | 36 | 5 | M20x2.5P  | 50 | 54 | 129 | --    |
| CLT-06                   | 37.5      | 33.2      | 15.1      | 7.6       | 101.5     | 81.5      | 31 | 12 | 36 | 4 | M16x2P    | 34 | 39 | 73  | --    |
| CLT-08                   | 46.3      | 41.9      | 22.1      | 8.6       | 127       | 106       | 35 | 14 | 36 | 5 | M20x2.5P  | 38 | 42 | 95  | 104.8 |
| CLT-10                   | 51.4      | 47        | 30.6      | 9.6       | 158       | 133       | 40 | 16 | 36 | 5 | M20x2.5P  | 45 | 46 | 110 | 133.4 |
| CLT-12                   | 60.63     | 55.32     | 48.55     | 20.05     | 163       | 133       | 50 | 18 | 36 | 5 | M20x2.5P  | 50 | 54 | 129 | --    |

| 型式/規格<br>MODEL<br>/SPEC. | 柱塞行程<br>Plunger<br>Stroke<br>(mm) | 爪行程<br>[直徑]<br>Jaw Stroke<br>[Diameter]<br>(mm) | 最高迴轉速<br>Max.Speed<br>r.p.m.(min <sup>-1</sup> ) | 最大拉力<br>Max. Pull<br>Force<br>kgf (kN) | 最大靜夾持力<br>Max. Gripping<br>Force<br>kgf (kN) | 最大設定<br>油壓壓力<br>Max. Hydr.<br>Pressure<br>kgf/cm <sup>2</sup> (MPa) | 夾持範圍<br>Gripping<br>Range | 搭配<br>油壓缸型號<br>Matching<br>Cylinder | 淨重<br>Weight<br>(kg) |
|--------------------------|-----------------------------------|---|--|--|--|---|---------------------------|-------------------------------------|----------------------|
| CL-05                    | 15                                | 6.4   | 5500   | 800 (7.8)                              | 2450 (24)                                    | 25 (2.5)  | ø8~ø135                   | L0815                               | 6                    |
| CL-06                    | 20                                | 8.5   | 5000   | 1730 (17)                              | 5200 (51)                                    | 25 (2.5)  | ø18~ø165                  | L1020(L1020R)                       | 11.4                 |
| CL-08                    | 21                                | 8.8   | 4600   | 2440 (24)                              | 7440 (73)                                    | 25 (2.5)  | ø12~ø210                  | L1225(L1225R)                       | 21.9                 |
| CL-10                    | 25                                | 8.8   | 4000   | 2850 (28)                              | 10810 (106)                                  | 29 (2.8)  | ø16~ø254                  | L1225(L1225R)                       | 33.4                 |
| CL-12                    | 30                                | 10.5  | 3200   | 4080 (40)                              | 15500 (152)                                  | 29 (2.8)  | ø18~ø304                  | L1530(L1530R)                       | 58.5                 |
| CLT-06                   | 20                                | 8.5   | 5000   | 1220 (12)                              | 3460 (34)                                    | 17 (1.7)  | ø9~ø165                   | L1020(L1020R)                       | 11.1                 |
| CLT-08                   | 21                                | 8.8   | 4000   | 1630 (16)                              | 4990 (49)                                    | 16 (1.6)  | ø12~ø210                  | L1225(L1225R)                       | 21.3                 |
| CLT-10                   | 25                                | 8.8   | 3500   | 1930 (19)                              | 7140 (70)                                    | 19 (1.9)  | ø15~ø254                  | L1225(L1225R)                       | 32.6                 |
| CLT-12                   | 30                                | 10.5  | 3000   | 2750 (27)                              | 10300 (101)                                  | 20 (2.0)  | ø20~ø304                  | L1530(L1530R)                       | 57.0                 |