

OPBT, OPBF LARGE THROUGH HOLE HIGH SPEED POWER CHUCKS

大孔徑二爪
大孔徑四爪
高速中空油壓夾頭

新產品
NEW



尺寸圖 > Dimensions

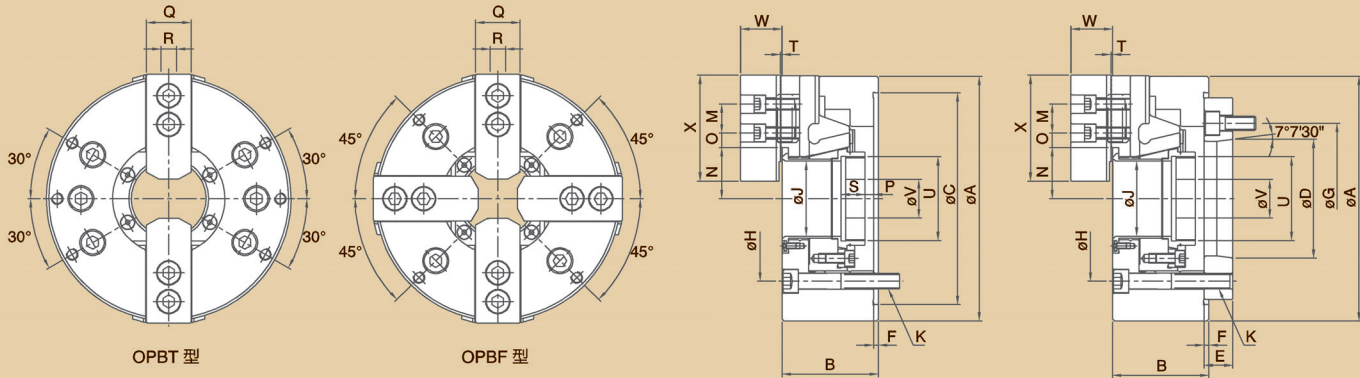

規格表 > Specifications

單位/UNIT:mm

型式/規格 MODEL /SPEC.	主軸鼻端番號 Nose Of Spindle	A	B	C (H6)	D	E	F	G	H	J
OPBT-206	A ₂ -5	170	81	140	82.563	20	5	PCDø104.8	PCDø122	52
OPBT-208	A ₂ -6	215	91	170	106.375	22	5	PCDø133.4	PCDø150	66
OPBT-210	A ₂ -8	256	100	220	139.719	28	5	PCDø171.4	PCDø180	81
OPBF-206	A ₂ -5	170	81	140	82.563	20	5	PCDø104.8	PCDø122	52
OPBF-208	A ₂ -6	215	91	170	106.375	22	5	PCDø133.4	PCDø150	66
OPBF-210	A ₂ -8	256	100	220	139.719	28	5	PCDø171.4	PCDø180	81

型式/規格 MODEL /SPEC.	K	M	N max.	N min.	O max.	O min.	P max.	P min.	Q	R	S
OPBT-206	6-M10x1.5P	20	36.35	33.6	21.1	7.55	7	-5	31	12	23
OPBT-208	6-M12x1.75P	25	46.6	42.9	26.6	11.6	10	-6	35	14	25
OPBT-210	6-M16x2P	30	54.6	50.1	33.55	11.05	8.5	-10.5	40	16	25
OPBF-206	4-M10x1.5P	20	36.35	33.6	21.1	7.55	7	-5	31	12	23
OPBF-208	4-M12x1.75P	25	46.6	42.9	26.6	11.6	10	-6	35	14	25
OPBF-210	4-M16x2P	30	54.6	50.1	33.55	11.05	8.5	-10.5	40	16	25

型式/規格 MODEL /SPEC.	T	U	V	W	X	通孔直徑 Thru-Hole [Diameter] (mm)	柱塞行程 Plunger Stroke (mm)	爪行程(直徑) Jaw Stroke [Diameter] (mm)
OPBT-206	2	M60x2P	20	37.5	73	52	12	5.5
OPBT-208	2	M75x2P	30	39.5	80	66	16	7.4
OPBT-210	2	M90x2P	40	43	110	81	19	8.8
OPBF-206	2	M60x2P	20	37.5	73	52	12	5.5
OPBF-208	2	M75x2P	30	39.5	80	66	16	7.4
OPBF-210	2	M90x2P	40	43	110	81	19	8.8

型式/規格 MODEL /SPEC.	最高迴轉速 Max. Speed r.p.m.(min ⁻¹)	最大拉力 Max. Pull Force		最大靜夾持力 Max. Gripping Force		最大設定油壓壓力 Max. Hydr. Pressure		夾持範圍 Gripping Range	搭配 油壓缸型號 Matching Cylinder	淨重 Weight (kg)
		kgf	(kN)	kgf	(kN)	kgf/cm ²	(MPa)			
OPBT-206	6000	1550	(15)	3950	(38.5)	15	(1.4)	ø13~ø170	P1452S	11.85
OPBT-208	5000	2250	(22)	5850	(57)	17	(1.6)	ø50~ø215	P1666S	21.2
OPBT-210	4200	2900	(28)	7400	(72.5)	19.5	(1.9)	ø34~ø254	P1881S	32.85
OPBF-206	4500	1700	(16.5)	4400	(42.5)	16	(1.5)	ø22~ø170	P1452S	13
OPBF-208	3600	2500	(24.5)	6450	(63)	19	(1.8)	ø50~ø215	P1666S	22.6
OPBF-210	3200	3200	(31)	8200	(80)	21.5	(2.1)	ø32~ø254	P1881S	35.35