

方型超薄夾盤

1. MC 均為定寸研磨方式；任何相同規格之方型夾盤 W,X,Y,Z 各點之高度公差為0.05mm以內。
2. MC規格均可替換生爪，作不規則形狀之加工，以替代中心機大量治具，更經濟、方便。
3. 硬爪重複夾持之精度公差為0.02mm 以內。
4. 側邊平行校正後，硬爪夾持之平行公差為0.05mm以內。

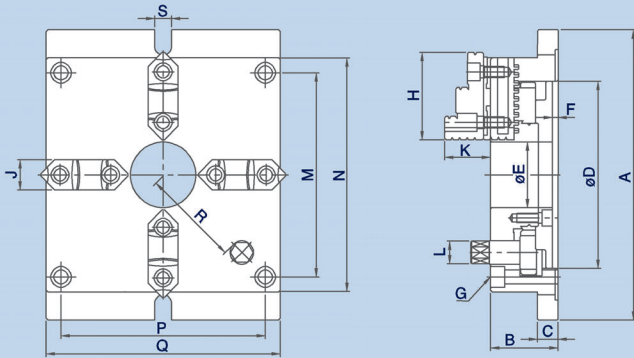

尺寸圖 » Dimensions



1. MC chucks are precisely ground, the tolerances of W,X,Y,Z among chucks are within 0.05mm.
2. Soft jaws can be used alternatively for machining special shaped work pieces, to substitute for designing and making a lot of jigs for this purpose.
3. The repetitive gripping accuracy with the hard jaws are within 0.02mm.
4. Parallel gripping accuracy with hard jaws can be controlled within 0.05mm after aligning sides of chucks.

使用範例 » Operation Example

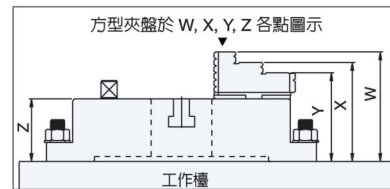

規格表 » Specifications

單位/UNIT:mm

型式/規格 MODEL /SPEC.	A	B	C	D	E	F	G	H	J	K	L	M
MC-06	215	57	18	130	40	5.5	4-M10x1.5P	68	26	39	14	144
MC-08	250	65	20	160	55	6	4-M12x1.75P	82	28	43	17	174
MC-10	310	72	22	200	70	6	4-M14x2P	93	32	50	21	218
MC-12	380	85	25	260	100	7	4-M16x2P	118	40	56	23	274

型式/規格 MODEL /SPEC.	N	P	Q	R	S	把握範圍 Max.Gripping Diameter		淨重 Weight (kg)
						外徑把握 O.D.Clamping (mm)	內徑把握 I.D.Clamping (mm)	
MC-06	165	144	165	66	18	ø4-ø128	ø55-ø128	11.4
MC-08	200	174	200	83	18	ø5-ø162	ø62-ø162	18.6
MC-10	250	218	250	104	18	ø6-ø200	ø72-ø200	31.6
MC-12	310	274	310	135	22	ø10-ø265	ø90-ø265	56.6