

L-RE SOLID ROTARY HYDRAULIC CYLINDERS (BUILT-IN CHECK VALVE & SENSOR)

中實油壓迴轉缸 (附止逆及檢知裝置)

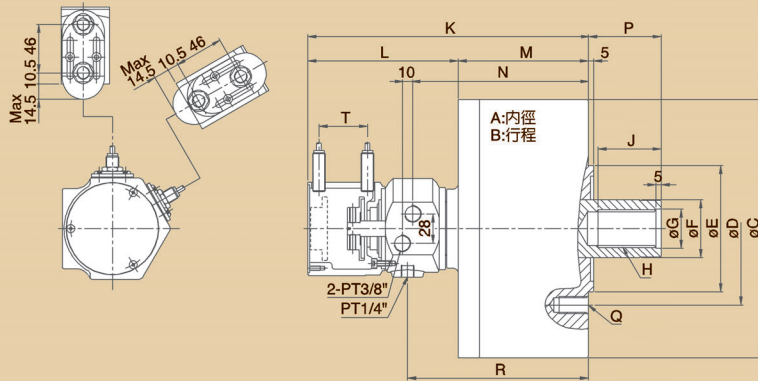

尺寸圖 » Dimensions



註：近接開關為特殊附件
Note: Proximity switch is an extra option.

規格表 » Specifications

單位/UNIT:mm

型式/規格 MODEL / SPEC.	A	B	C	D	E (h7)	F	G (H8)	H	
L1225RE	125	25	160	130	110	35	25	M24x3P	
L1530RE	150	30	190	130	110	45	31	M30x3.5P	
L2035RE	200	35	245	145	120	55	37	M36x4P	
型式/規格 MODEL / SPEC.	J	K	L	M	N	P max.	P min.		
L1225RE	45	239.5	145.5	94	140	51	26		
L1530RE	45	248.5	143.5	105	149	56	26		
L2035RE	60	266	142.5	123.5	166.5	69	34		
型式/規格 MODEL / SPEC.	Q	R	T	活塞行程 Piston Stroke (mm)	最高迴轉速 Max. Speed r.p.m (min ⁻¹)	慣性矩 Moment of Inertia (kg·m ²)	流量 Oil Leakage Rate (ℓ/min)		
L1225RE	6-M12x1.75P	145	46	25	6000	0.023	0.8		
L1530RE	12-M12x1.75P	154	46	30	5500	0.048	0.8		
L2035RE	12-M16x2P	171.5	46	35	5500	0.098	0.8		
型式/規格 MODEL / SPEC.	最高使用壓力 Max. Pressure kgf/cm ² (MPa)		活塞面積 Piston Area (cm ²) 推力側 Push Side		最大推(拉)力 Max. Operating Force 推力側 Push Side kgf (kN)		淨重 Weight (kg)		
L1225RE	40	(3.9)	120	113	4400	(43.1)	4100	(40.2)	9.7
L1530RE	40	(3.9)	174	160	6200	(60.8)	5700	(55.9)	13.7
L2035RE	40	(3.9)	312	290	11200	(109.8)	10400	(102.0)	23.3

★流量測試標準-壓力:30kgf/cm²(2.94MPa) 油溫:50°C ★Test standard of oil leakage: Pressure-30 kgf/cm²(2.94MPa), Oil temperature-50°C