

# CL-DP 3-JAW SOLID CHUCK WITH ANTI-CHIPS SEALED

## 三爪中實油壓夾頭

防塵專利結構可以防止鐵屑進入本體內部。  
Dustproof patent structure can prevent the metal chips get into chuck inside.

新產品  
**NEW**



### 尺寸圖 >> Dimensions

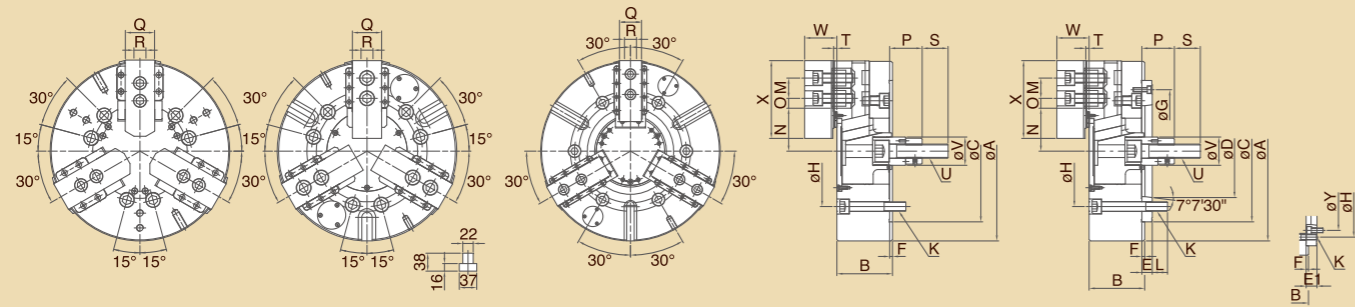

CL-12DP 型      CL-15DP, 18DP 型      CL-21DP, 24DP, 32DP, 40DP 型

### 規格表 >> Specifications

型式/規格 MODEL /SPEC.	主軸鼻端番號 Nose Of Spindle	A	B	C (h6)	D	E	E1	F	G	H	K	L	M
CL-12DP	A <sub>2</sub> -8	304	110	220	139.719	18	--	6	190	171.4	6-M16x2P	20	30
CL-15DP	A <sub>2</sub> -11	381	118	300	196.869	22	--	6	260	235	6-M20x2.5P	32	43
CL-18DP	A <sub>2</sub> -11	450	118	300	196.869	22	--	6	260	235	6-M20x2.5P	32	43
CL-21DP	A <sub>2</sub> -15(A <sub>2</sub> -11)	530	129	380	285.775	27	41	6	330.2	330.2	6-M24x3P	33	60
CL-24DP	A <sub>2</sub> -15(A <sub>2</sub> -11)	610	129	380	285.775	27	41	6	330.2	330.2	6-M24x3P	33	60
CL-32DP	A <sub>2</sub> -15(A <sub>2</sub> -11)	800	129	380	285.775	27	41	6	330.2	330.2	6-M24x3P	33	60
CL-40DP	A <sub>2</sub> -15(A <sub>2</sub> -11)	1000	129	380	285.775	27	41	6	330.2	330.2	6-M24x3P	33	60

型式/規格 MODEL /SPEC.	N max.	N min.	O max.	O min.	P max.	P min.	Q	R	S	T	U	V	W	X	Y
CL-12DP	60.63	55.32	48.55	20.05	163	133	50	18	36	5	M20x2.5P	50	54	129	-
CL-15DP	69.05	60.97	58.05	40.05	104	69	62	25.5	55	7	M30x3.5P	60	68	165	---
CL-18DP	99.46	91.38	58.05	40.05	92	57	62	25.5	55	7	M30x3.5P	60	68	165	--
CL-21DP	80.49	72.41	101.8	41.8	96.95	61.95	65	25	55	7	M30x3.5P	60	75.5	180	235
CL-24DP	119.49	111.41	101.8	41.8	96.95	61.95	65	25	55	7	M30x3.5P	60	75.5	180	235
CL-32DP	119.49	111.39	197.8	41.8	97	61.95	65	25	55	7	M30x3.5P	60	75.5	180	235
CL-40DP	119.49	111.39	299.8	41.8	97	62	65	25	55	7	M30x3.5P	60	75.5	180	235

型式/規格 MODEL /SPEC.	柱塞行程 Plunger Stroke (mm)	爪行程 (直徑) Jaw Stroke [Diameter] (mm)	最高迴轉速 Max.Speed r.p.m.(min <sup>-1</sup> )	最大拉力 Max. Pull Force (kN)	最大靜夾持力 Max. Gripping Force (kN)	最大設定 油壓壓力 Max. Hydr. Pressure kgf/cm <sup>2</sup> (MPa)	淨重 Weight (kg)	搭配 油壓缸型號 Matching Cylinder	夾持範圍 Gripping Range			
CL-12DP	30	10.5	3200	4080	(40)	15500	(152)	29	(2.8)	64.4	L1530(L1530RE)	ø18~ø304
CL-15DP	35	16	3000	8260	(81)	25290	(248)	32	(3.1)	104.1	L2035(L2035RE)	ø68~ø381
CL-18DP	35	16	2700	8260	(81)	25290	(248)	32	(3.1)	138.5	L2035(L2035RE)	ø100~ø450
CL-21DP	35	16	1900	8650	(85)	27000	(265)	33	(3.2)	204.8	L2035(L2035RE)	ø80~ø530
CL-24DP	35	16	1700	8650	(85)	27000	(265)	33	(3.2)	260	L2035(L2035RE)	ø155~ø610
CL-32DP	35	16	1100	8650	(85)	27000	(265)	33	(3.2)	455.4	L2035(L2035RE)	ø155~ø800
CL-40DP	35	16	800	8650	(85)	27000	(265)	33	(3.2)	--	L2035(L2035RE)	ø155~ø1000

# VL-DP 3-JAW SOLID CHUCK WITH ANTI-CHIPS SEALED & WATER-PROOF FLANGE PLATE FOR VERTICAL LATHE

## 立車用中實油壓夾頭 (含連結板)

- 1.防塵專利結構可以防止鐵屑進入本體內部。
- 2.清潔孔設計可以吹氣強制帶出夾頭內部殘留細屑及切屑液。
- 3.排水盤結構設計，防止切屑液進入主軸內部。

新產品  
**NEW**

專利產品  
**Patent Protected**



### 尺寸圖 >> Dimensions

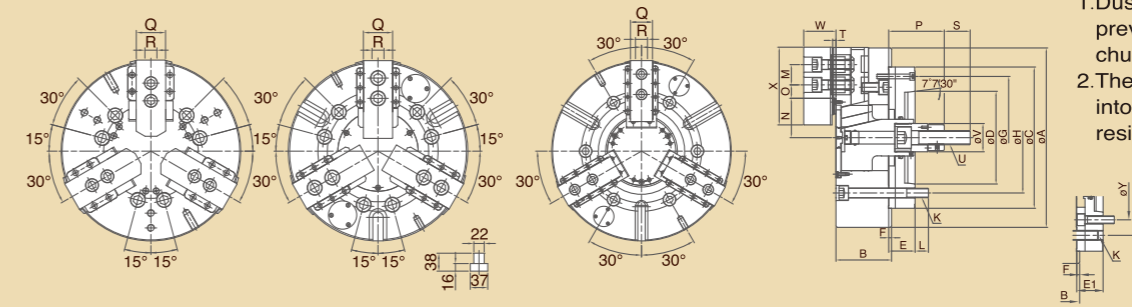

VL-12DP 型      VL-15DP, 18DP 型      VL-21DP, 24DP, 32DP 型

1. Dustproof patent structure can prevent the metal chips get into chuck inside.
2. The clean hole design can blow air into chuck internal to clean out the residual chips and coolant.
3. The drainage plate structure design can prevent the coolant get into spindle internal.

### 規格表 >> Specifications

型式/規格 MODEL /SPEC.	主軸鼻端番號 Nose Of Spindle	A	B	C (h6)	D	E	E1	F	G	H	K	L	M
VL-12DP	A <sub>2</sub> -8(A <sub>2</sub> -6)	304	110	220	139.719	38	38	6	190	171.4	6-M16x2P	20	30
VL-15DP	A <sub>2</sub> -11(A <sub>2</sub> -8)	381	118	300	196.869	54	54	6	260	235	6-M20x2.5P	30	43
VL-18DP	A <sub>2</sub> -11(A <sub>2</sub> -8)	450	118	300	196.869	48	48	6	260	235	6-M20x2.5P	26	43
VL-21DP	A <sub>2</sub> -15(A <sub>2</sub> -11)	530	129	380	285.775	55	50	6	330.2	330.2	6-M24x3P	36	60
VL-24DP	A <sub>2</sub> -15(A <sub>2</sub> -11)	610	129	380	285.775	55	50	6	330.2	330.2	6-M24x3P	36	60
VL-32DP	A <sub>2</sub> -15(A <sub>2</sub> -11)	800	129	380	285.775	55	50	6	330.2	330.2	6-M24x3P	36	60

型式/規格 MODEL /SPEC.	N max.	N min.	O max.	O min.	P max.	P min.	Q	R	S	T	U	V	W	X	Y
VL-12DP	60.63	55.32	48.55	20.05	183	153	50	18	36	5	M20x2.5P	50	54	129	133.4
VL-15DP	69.05	60.97	58.05	40.05	136	101	62	25.5	55	7	M30x3.5P	60	68	165	171.4
VL-18DP	99.46	91.38	58.05	40.05	130	96	62	25.5	55	7	M30x3.5P	60	68	165	171.4
VL-21DP	80.49	72.41	101.8	41.8	132	97	65	25	55	7	M30x3.5P	60	75.5	180	235
VL-24DP	119.49	111.41	101.8	41.8	132	97	65	25	55	7	M30x3.5P	60	75.5	180	235
VL-32DP	119.49	111.39	197.8	41.8	132	97	65	25	55	7	M30x3.5P	60	75.5	180	235

型式/規格 MODEL /SPEC.	柱塞行程 Plunger Stroke (mm)	爪行程 (直徑) Jaw Stroke [Diameter] (mm)	最高迴轉速 Max.Speed r.p.m.(min <sup>-1</sup> )	最大拉力 Max. Pull Force (kN)	最大靜夾持力 Max. Gripping Force (kN)	最大設定 油壓壓力 Max. Hydr. Pressure kgf/cm <sup>2</sup> (MPa)	淨重 Weight (kg)	搭配 油壓缸型號 Matching Cylinder	夾持範圍 Gripping Range			
VL-12DP	30	10.5	3200	4080	(40)	15500	(152)	29	(2.8)	64.4	L1530(L1530RE)	ø18~ø304
VL-15DP	35	16	3000	8260	(81)	25290	(248)	32	(3.1)	104.1	L2035(L2035RE)	ø68~ø381
VL-18DP	35	16	2700	8260	(81)	25290	(248)	32	(3.1)	138.5	L2035(L2035RE)	ø100~ø450
VL-21DP	35	16	1900	8650	(85)	27000	(265)	33	(3.2)	204.8	L2035(L2035RE)	ø80~ø530
VL-24DP	35	16	1700	8650	(85)	27000	(265)	33	(3.2)	260	L2035(L2035RE)	ø155~ø610
VL-32DP	35	16	1100	8650	(85)	27000	(265)	33	(3.2)	455.4	L2035(L2035RE)	ø155~ø800